

**INSTITUTO DE CIENCIAS
DE LA CONSTRUCCIÓN
EDUARDO TORROJA**

C/ Serrano Galvache n. 4 28033 Madrid (Spain)
Tel.: (34) 91 302 04 40 Fax: (34) 91 302 07 00
direccion.ietcc@csic.es <https://dit.ietcc.csic.es>

European Technical Assessment

**ETA 14/0374
of 18/02/2019**

English translation prepared by IETcc. Original version in Spanish language

General Part

Technical Assessment Body issuing the ETA designated according to Art. 29 of Regulation (EU) 305/2011

Instituto de Ciencias de la Construcción Eduardo Torroja (IETcc)

Trade name of the construction product

Anchor Sissy Stud

Product family to which the construction product belongs

Concrete screw of sizes 7.5, 10.5, 12.5 and 16.5 for use in cracked and non-cracked concrete.

Manufacturer

Joker Industrial Co. Ltd.
No 10 Changbin East 7rd.
Changbin Industrial District.
Hsien Hsi. Hsiang. Changua Hsien.
Taiwan R.O.C.
website: www.joker.com.tw

Manufacturing plants

Joker Industrial Co. Ltd.
No 10 Changbin East 7rd.
Changbin Industrial District.
Hsien Hsi. Hsiang. Changua Hsien.
Taiwan R.O.C.

This European Technical Assessment contains

15 pages including 4 annexes which form an integral part of this assessment.

This European Technical Assessment is issued in accordance with regulation (EU) No 305/2011, on the basis of

European Technical Assessment EAD 330232-00-0601 "Mechanical Fasteners for use in concrete", ed. October 2016

This version replaces

ETA 14/0374 issued on 23/09/2016

English translation prepared by IETcc

This European Technical Assessment is issued by the Technical Assessment Body in its official language. Translations of this European Technical Assessment in other languages shall fully correspond to the original issued document and should be identified as such.

This European Technical Assessment may be withdrawn by the issuing Technical Assessment Body, in particular pursuant to information by the Commission according to article 25 (3) of Regulation (EU) No 305/2011.

English translation prepared by IETcc

SPECIFIC PART

1. Technical description of the product

The Sissy Stud concrete screw is an anchor made of carbon steel. The anchor is made in sizes 7.5, 10.5, 12.5 and 16.5, and is screwed into a predrilled cylindrical drill hole. The special thread of the anchor cuts an internal thread into the member while setting. The anchorage is characterised by mechanical interlock in the special thread.

Product and product description is given in annex A.

2. Specification of the intended use in accordance with the applicable European Assessment Document.

The performances given in section 3 are only valid if the anchor is used in compliance with the specifications and conditions given in annex B.

The verifications and assessment methods on which this European Technical Assessment is based lead to the assumption of a working life of the anchor of at least 50 years. The indications given on the working life cannot be interpreted as a guarantee given by the producer, but are to be regarded only as a means to choosing the right products in relation to the expected economically reasonable working life of the works.

3. Performance of the product and references to the methods used for its assessment

3.1 Mechanical resistance and stability (BWR 1)

Essential characteristic	Performance
Sissy Stud performance for static or quasi static actions	See annex C

3.2 Safety in case of fire (BWR 2)

Essential characteristic	Performance
Reaction to fire	Anchorage satisfy requirements for class A1
Resistance to fire	See annex D

4. Assessment and verification of constancy of performance (hereinafter AVCP) system applied, with reference to its legal base

The applicable European legal act for the system of Assessment and Verification of Constancy of Performances (see annex V of Regulation (EU) No 305/2011) is 96/582/EC.

The system to be applied is 1.

English translation prepared by IETcc

5. Technical details necessary for the implementation of the AVCP system, as provided for in the applicable European Assessment Document.

The technical details necessary for the implementation of the AVCP system are laid down in the quality plan deposited at Instituto de Ciencias de la Construcción Eduardo Torroja.



Instituto de Ciencias de la Construcción Eduardo Torroja
CONSEJO SUPERIOR DE INVESTIGACIONES CIENTÍFICAS

C/ Serrano Galvache n.º 4. 28033 Madrid.
Tel: (+34) 91 302 04 40 Fax: (+34) 91 302 07 00

<https://dit.ietcc.csic.es>



On behalf of the Instituto de Ciencias de la Construcción Eduardo Torroja
Madrid, 18th of February 2019



Director IETcc-CSIC





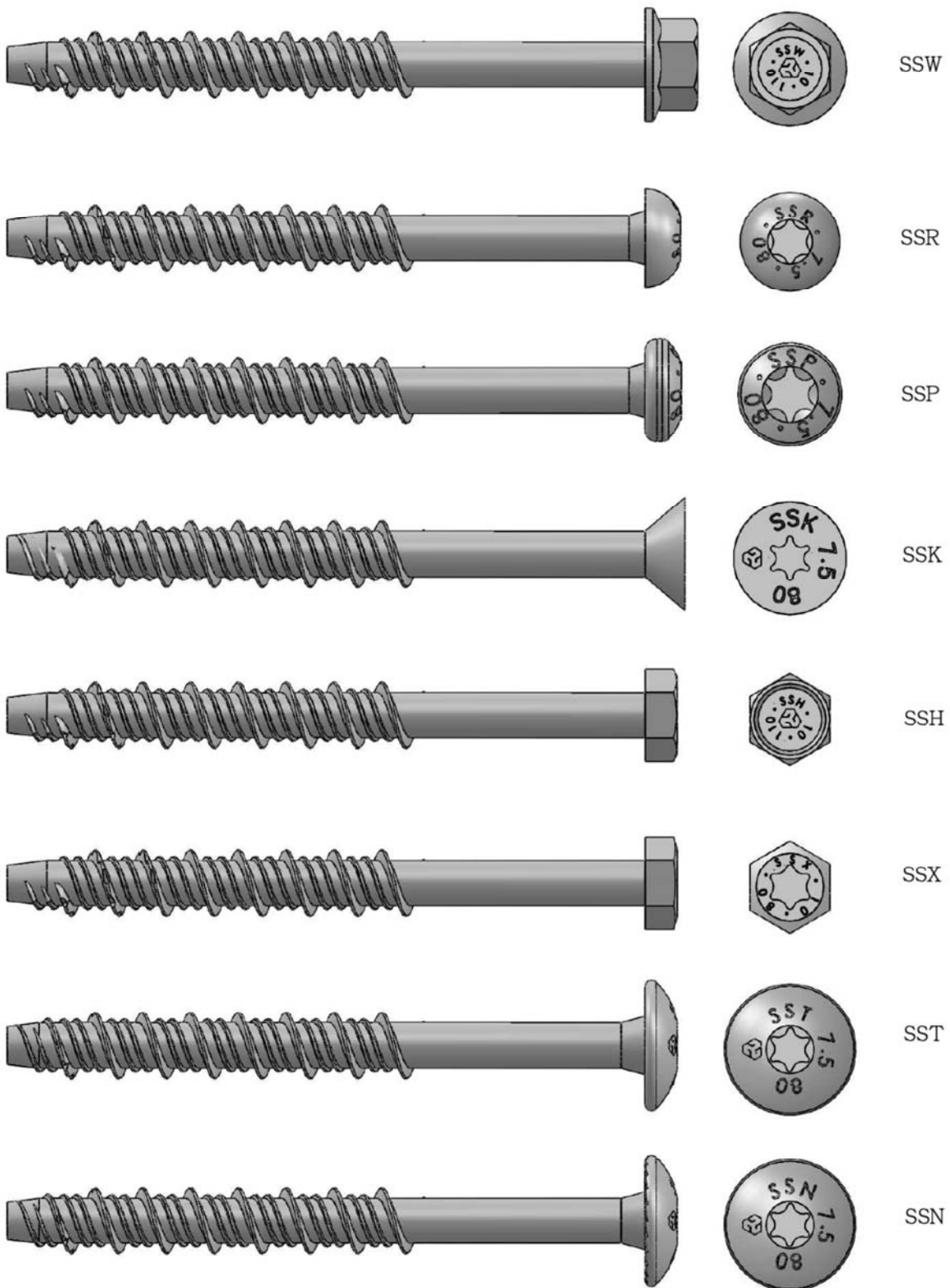











English translation prepared by IETcc

Product and identification

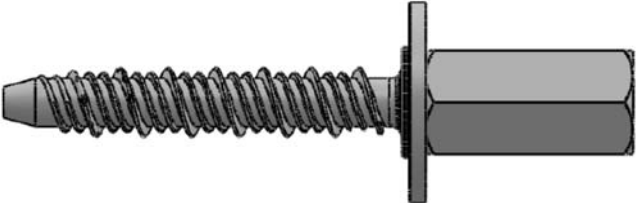

Sissy Stud	
Product description Identification	Annex A1

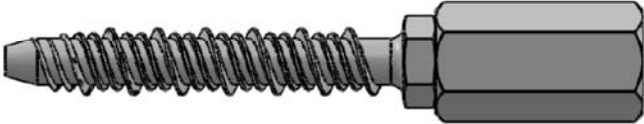
English translation prepared by IETcc

		SSD
		SSI
		SSF
		SSO
		SSU
		SSG
		SSQ
		SSV

Sissy Stud	Annex A2
Product description	
Identification	

English translation prepared by IETcc

Marking/Identification on anchor:

- Company logo
- Outer diameter
- Length
- Anchor type:
 - Hex head with washer SSW
 - Round head SSR
 - Pan head SSP
 - Countersunk head SSK
 - Hex head SSH
 - Hex head, hexalobular recess SSX
 - Truss head SST
 - Truss head with underhead ribs SSN
 - Connection thread with hexagon drive SSD
 - Internal thread SSI
 - Flat washer head with connection thread SSF
 - Hex washer head with connection thread SSO
 - Hex head with connection thread SSU
 - SSF flex with coupler nut SSG
 - SSO flex with coupler nut SSQ
 - SSU flex with coupler nut SSV

Table A1: Materials

Item	Designation	Sissy Stud
1	Anchor Body	Carbon steel wire rod cold forged. Allowed coatings: <ul style="list-style-type: none"> • Zinc plated ISO 4042 • Silver ruspert • Zinc flake EN 10683

Sissy Stud	Annex A3
Product description	
Identification	

English translation prepared by IETcc

Installed condition

- h_{ef} : Effective anchorage depth
- h_1 : Depth of drilled hole
- h_{nom} : Overall anchor embedment depth in the concrete
- h_{min} : Minimum thickness of concrete member
- t_{fix} : Thickness of fixture
- d_0 : Nominal diameter of drill bit
- d_f : Diameter of clearance hole in fixture

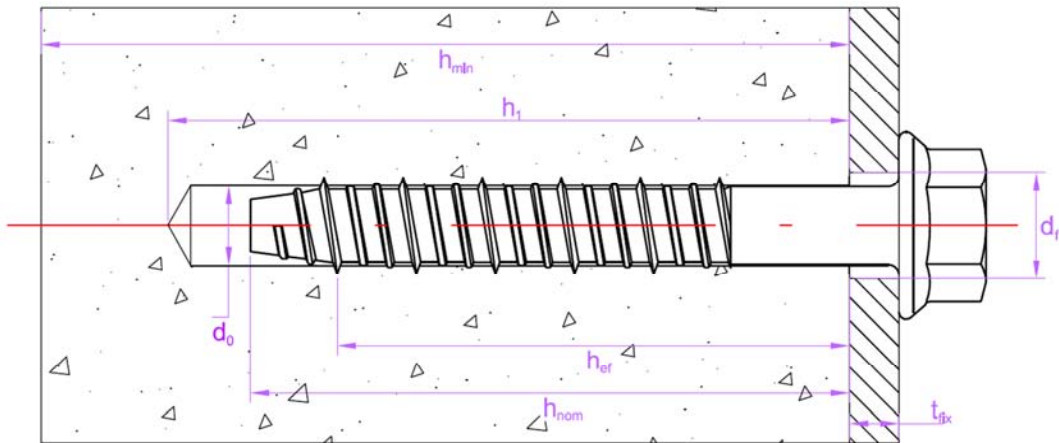

Drawing A1. Installed condition for anchors SSW, SSR, SSP, SSK, SSH, SSX, SST and SSN.

Sissy Stud	Annex A4
Product description	
Installed condition	

English translation prepared by IETcc

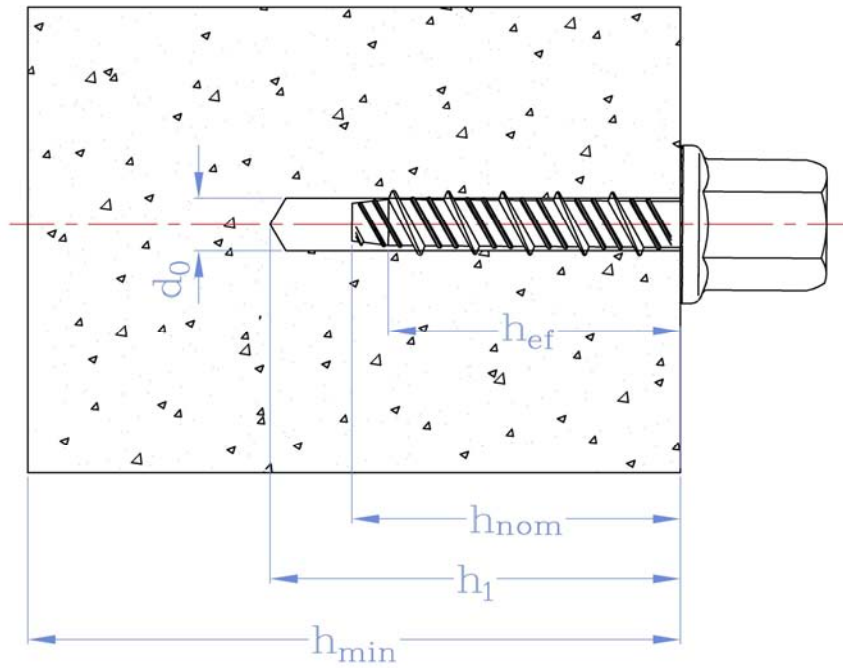

Drawing A2. Installed condition for anchors SSD, SSI, SSF, SSO, SSU, SSG, SSQ and SSV

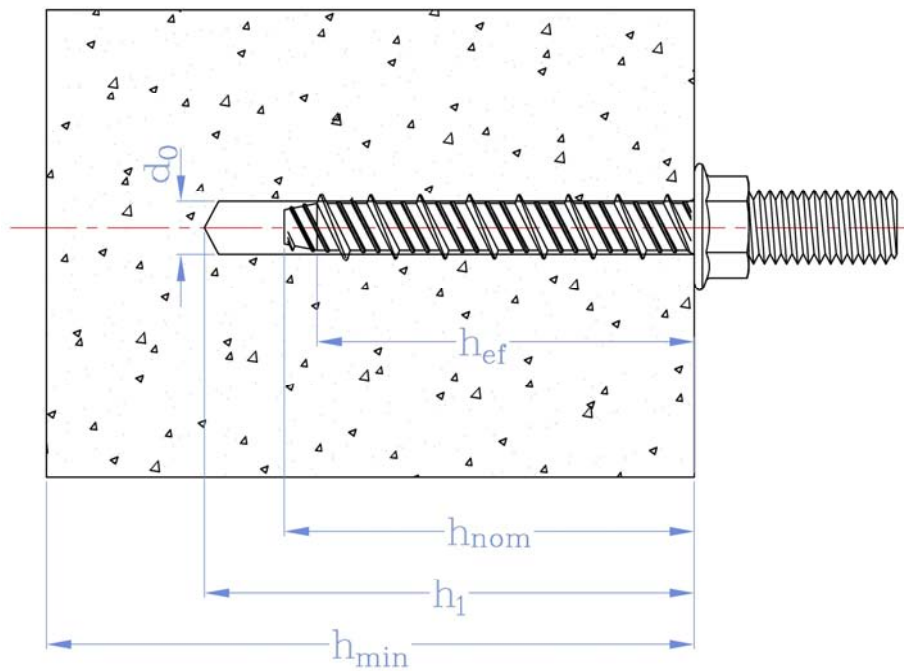

Drawing A3. Installed condition for anchors SSD, SSI, SSF, SSO, SSU, SSG, SSQ and SSV

Sissy Stud	Annex A5
Product description	
Installed condition	

Intended use

Anchorage subjected to:

- Static or quasi static loads: all sizes and embedment depths.

Base materials:

- Reinforced and unreinforced concrete according to EN 206-1.
- Strength classes C20/25 to C50/60 according to EN 206-1.
- Cracked and uncracked concrete.

Use conditions (environmental conditions):

- The anchor shall be used in dry internal conditions.
- The anchor may be used for anchorages with requirements related to resistance to fire.

Design:

- Anchorages are designed under the responsibility of an engineer experienced in anchorages and concrete.
- Verifiable calculation rules and drawings are prepared taking into account of the loads to be attached. The position of the anchor is indicated on the design drawings (e.g. position of the anchor relative to reinforcement or to supports, etc.)
- Anchorages under static or quasi-static loads are designed for design Method A in accordance with:
 - EN 1992-4:2018

Installation:

- Hammer drilling only.
- Anchor installation carried out by appropriately qualified personal and under the supervision of the person responsible for technical matters of the site.
- In case of aborted hole: new drilling at a minimum distance away of twice the depth of aborted hole or smaller distance if the aborted hole is filled with high strength mortar and if under shear or oblique tension load it is not the direction of the load application.
- After installation further turning of the anchor is not possible. The head of the anchor is supported on the fixture, as it is shown in Drawing B1, and it is not damaged.

Sissy Stud	Annex B1
Intended use	
Specifications	

Table B1: Installation parameters

Installation parameters			Performance			
			SS 7.5	SS 10.5	SS 12.5	SS 16.5
d_0	Nominal diameter of drill bit:	[mm]	6	8	10	14
d_f	Diameter of clearance hole in fixture:	[mm]	9	12	14	18
d_s	Outer diameter of the thread	[mm]	7.5	10.5	12.5	16.5
L_{min}	Total length of the anchor	[mm]	60	65	75	115
L_{max}		[mm]	400	400	400	400
h_{min}	Minimum thickness of concrete member:	[mm]	100	100	105	175
h_1	Depth of drilled hole:	[mm]	65	70	85	130
h_{nom}	Overall anchor embedment depth in the concrete:	[mm]	55	60	70	110
h_{ef}	Effective anchorage depth:	[mm]	42	45	52	86
T_{ins}	Installation torque	[Nm]	20	50	80	120
t_{fix}	Thickness of fixture	[mm]	L-55	L-60	L-70	L-110
s_{min}	Minimum allowable spacing:	[mm]	45	50	60	100
c_{min}	Minimum allowable edge distance:	[mm]	45	50	60	100

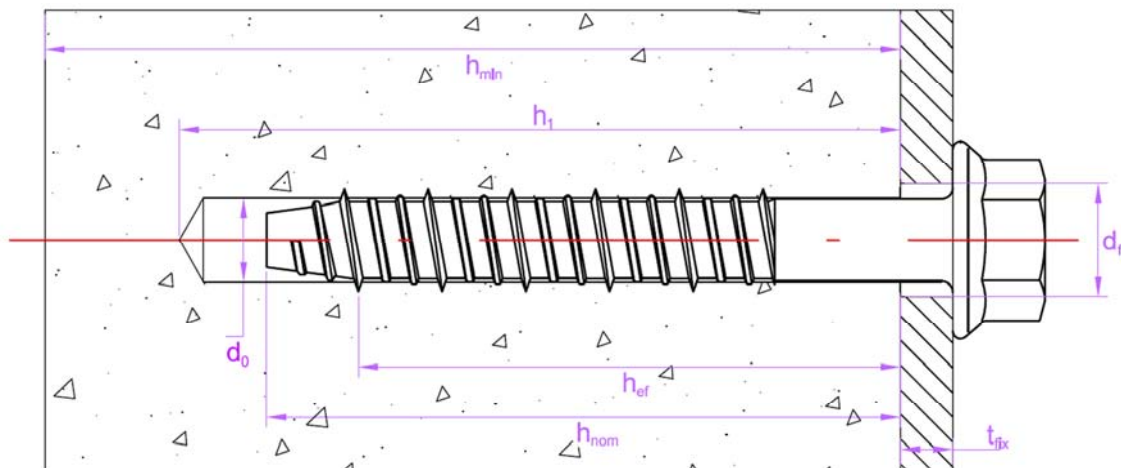

Drawing B1. Installed condition for anchors SSW, SSR, SSP, SSK, SSH, SSX, SST and SSN

Installation process

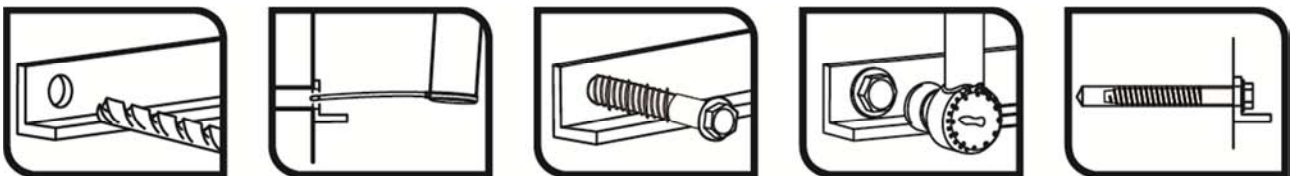

Anchor shall be installed using a torque wrench or an electrical impact driver; power input: 500 W; torque: 50-250 Nm. (e.g: Bosch GDS 18E)

Sissy Stud

Performances

Installation parameters and installation procedure

Annex B2

Table C1: Characteristic values to tension loads of design method A

Characteristic values of resistance to tension loads of design method A			Performance			
			SS 7.5	SS 10.5	SS 12.5	SS 16.5
Tension loads: steel failure						
$N_{Rk,s}$	Tension steel characteristic resistance:	[kN]	18.7	32.7	51.2	115.9
γ_{Ms}	Partial safety factor:*)	[-]	1.5	1.5	1.5	1.5
Tension loads: pull-out failure in concrete						
$N_{Rk,p,ucr}$	Tension characteristic resistance in C20/25 uncracked concrete:	[kN]	9	12	20	40
$\psi_{c,ucr}$	C30/37	[-]	1,22	1,09	1,06	1,04
$\psi_{c,ucr}$	C40/45	[-]	1,41	1,07	1,10	1,06
$\psi_{c,ucr}$	C50/60	[-]	1,58	1,22	1,13	1,08
$N_{Rk,p,cr}$	Tension characteristic resistance in C20/25 cracked concrete:	[kN]	6	9	12	30
$\psi_{c,cr}$	C30/37	[-]	1,22	1,09	1,06	1,04
$\psi_{c,cr}$	C40/45	[-]	1,41	1,07	1,10	1,06
$\psi_{c,cr}$	C50/60	[-]	1,58	1,22	1,13	1,08
γ_{inst}	Installation safety factor	[-]	1.2	1.2	1.2	1
Tension loads: concrete cone and splitting failure						
h_{ef}	Effective embedment depth:	[mm]	42	45	52	86
γ_{ins}	Installation safety factor: *)	[-]	1.2	1.2	1.2	1
$s_{cr,N}$	Critical spacing:	[mm]	126	135	156	258
$c_{cr,N}$	Critical edge distance:	[mm]	63	67	78	129
$s_{cr,sp}$	Critical spacing (splitting):	[mm]	126	135	177	292
$c_{cr,sp}$	Critical edge distance (splitting):	[mm]	63	67	88	146

*) In absence of other national regulations

Table C2: Displacements under tension loads for Sissy Stud

Displacements under tension loads in uncracked concrete			Performance			
			SS 7.5	SS 10.5	SS 12.5	SS 16.5
N	Service tension load in uncracked concrete C20/25 to C50/60:	[kN]	3.6	4.8	9.5	19.0
$\bar{\delta}_{N0}$	Short term displacement under tension loads:	[mm]	0.4	0.4	0.4	0.9
$\bar{\delta}_{N\infty}$	Long term displacement under tension loads:	[mm]	1.0	1.1	1.4	1.4
Displacements under tension loads in cracked concrete			Performance			
			SS 7.5	SS 10.5	SS 12.5	SS 16.5
N	Service tension load in cracked concrete C20/25 to C50/60:	[kN]	2.4	3.6	5.7	11.9
$\bar{\delta}_{N0}$	Short term displacement under tension loads:	[mm]	0.6	0.7	0.5	0.6
$\bar{\delta}_{N\infty}$	Long term displacement under tension loads:	[mm]	1.4	1.2	1.4	1.2

Sissy Stud

Performances

Characteristic values for tension loads

Annex C1

Table C3: Characteristic values to shear loads of design method A

Characteristic values of resistance to shear loads of design method A		Performance			
		SS 7.5	SS 10.5	SS 12.5	SS 16.5
Shear loads: steel failure without lever arm					
$V_{Rk,s}$	Shear steel characteristic resistance: [kN]	7.5	16.3	35.6	57.9
γ_{Ms}	Partial safety factor: *)	1.25	1.25	1.25	1.25
Shear loads: steel failure with lever arm					
$M_{Rk,s}^0$	Characteristic bending moment: [Nm]	15.2	35.3	69.3	235.
γ_{Ms}	Partial safety factor: *)	1.25	1.25	1.25	1.25
Shear loads: concrete pryout failure					
K	K factor: [-]	1	1	1	2
γ_{inst}	Installation safety factor: *)	1	1	1	1
Shear loads: concrete edge failure					
l_f	Effective anchorage depth under shear loads: [mm]	42	45	52	86
d_{nom}	Outside anchor diameter: [mm]	7.5	10.5	12.5	16.5
γ_{inst}	Installation safety factor: *)	1	1	1	1

*) In absence of other national regulations

Table C4: Displacements under shear loads for Sissy Stud

Displacements under shear loads		Performances			
		SS 7.5	SS 10.5	SS 12.5	SS 16.5
V	Service shear load in cracked and uncracked concrete C20/25 to C50/60: [kN]	3.0	6.5	12.2	27.6
$\bar{\delta}_{V0}$	Short term displacement under shear loads: [mm]	1.3	1.4	1.8	2.3
$\bar{\delta}_{V\infty}$	Long term displacement under shear loads: [mm]	2.0	2.1	2.7	3.5

Sissy Stud

Performances

Characteristic values for shear loads
Displacements under tension and shear loads

Annex C2

English translation prepared by IETcc

Table D1: Characteristic values to fire resistance

Fire resistance duration = 30 minutes		SS 7.5	SS 10.5	SS 12.5	SS 16.5
Tension loads, steel failure					
$N_{Rk,s,fi,30}$	Characteristic resistance [kN]	0.23	0.61	1.28	2.90
Pull-out failure					
$N_{Rk,p,fi,30}$	Character. resistance in concrete C20/25 to C50/60 [kN]	1.50	2.25	3.00	7.50
Concrete cone failure **)					
$N_{Rk,c,fi,30}$	Character. resistance in concrete C20/25 to C50/60 [kN]	2.06	2.45	3.51	12.35
Shear loads steel failure without lever arm					
$V_{Rk,s,fi,30}$	Characteristic resistance [kN]	0.23	0.61	1.28	2.90
Shear loads, steel failure with lever arm					
$M_{Rk,s,fi,60}$	Characteristic bending resistance [Nm]	0.19	0.66	1.73	5.90

Fire resistance duration = 60 minutes		SS 7.5	SS 10.5	SS 12.5	SS 16.5
Tension loads, steel failure					
$N_{Rk,s,fi,60}$	Characteristic resistance [kN]	0.21	0.53	0.96	2.17
Pull-out failure					
$N_{Rk,p,fi,60}$	Character. resistance in concrete C20/25 to C50/60 [kN]	1.50	2.25	3.00	7.50
Concrete cone failure **)					
$N_{Rk,c,fi,60}$	Character. resistance in concrete C20/25 to C50/60 [kN]	2.06	2.45	3.51	12.35
Shear loads, steel failure without lever arm					
$V_{Rk,s,fi,60}$	Characteristic resistance [kN]	0.21	0.53	0.96	2.17
Shear loads, steel failure with lever arm					
$M_{Rk,s,fi,60}$	Characteristic bending resistance [Nm]	0.17	0.57	1.30	4.42

Fire resistance duration = 90 minutes		SS 7.5	SS 10.5	SS 12.5	SS 16.5
Tension loads, steel failure					
$N_{Rk,s,fi,90}$	Characteristic resistance [kN]	0.16	0.41	0.83	1.88
Pull-out failure					
$N_{Rk,p,fi,90}$	Character. resistance in concrete C20/25 to C50/60 [kN]	1.50	2.25	3.00	7.50
Concrete cone failure **)					
$N_{Rk,c,fi,90}$	Character. resistance in concrete C20/25 to C50/60 [kN]	2.06	2.45	3.51	12.35
Shear loads, steel failure without lever arm					
$V_{Rk,s,fi,90}$	Characteristic resistance [kN]	0.16	0.41	0.83	1.88
Shear loads, steel failure with lever arm					
$M_{Rk,s,fi,90}$	Characteristic bending resistance [Nm]	0.13	0.44	1.13	3.83

Sissy Stud

Performances
Characteristic values for fire resistance

Annex D1

English translation prepared by IETcc

Fire resistance duration = 120 minutes		SS 7.5	SS 10.5	SS 12.5	SS 16.5
Tension loads, steel failure					
$N_{Rk,s,fi,120}$	Characteristic resistance [kN]	0.12	0.33	0.64	1.45
Pull-out failure					
$N_{Rk,p,fi,120}$	Character. resistance in concrete C20/25 to C50/60 [kN]	1,20	1.80	2.40	6.00
Concrete cone failure **)					
$N_{Rk,c,fi,120}$	Character. resistance in concrete C20/25 to C50/60 [kN]	1.65	1.96	2.81	9.88
Shear loads, steel failure without lever arm					
$V_{Rk,s,fi,120}$	Characteristic resistance [kN]	0.12	0.33	0.64	1.45
Shear loads, steel failure with lever arm					
$M_{Rk,s,fi,120}$	Characteristic bending resistance [Nm]	0.10	0.35	0.87	2.95
Spacing and edge distances					
$S_{cr,N}$	Spacing [mm]	168	180	208	344
S_{min}	Minimum spacing [mm]	45	50	60	100
$C_{cr,N}$	Edge distance [mm]	84	90	104	172
C_{min}	Minimum edge distance (one side fire) [mm]	84	90	104	172
C_{min}	Minimum edge distance (two sides fire) [mm]	300	300	300	300
γ_{Msp}	Partial safety factor ^{*)} [-]	1.0	1.0	1.0	1.0
^{*)} In absence of other national regulations ^{**)} As a rule, splitting failure can be neglected when cracked concrete and reinforcement is assumed.					
Concrete pry-out failure		SS 7.5	SS 10.5	SS 12.5	SS 16.5
K factor	[-]	1	1	1	2
In Eq. (5.6) of EN 1992-4:2018, these values of k factor and the relevant values of $N_{Rk,c,fi}$ given in the above tables have to be considered in the design.					
Concrete edge failure					
The characteristic resistance $V_{Rk,c,fi}^0$ in C20/25 to C50/60 concrete is determined by: $V_{Rk,c,fi}^0 = 0,25 \times V_{Rk,c}^0 (\leq R90)$ and $V_{Rk,c,fi}^0 = 0,20 \times V_{Rk,c}^0 (R120)$ With $V_{Rk,c}^0$ initial value of the characteristic resistance in cracked concrete C20/25 under normal temperature according to EN 1992-4:2018.					
Sissy Stud					Annex D2
Performances Characteristic values for fire resistance					